

DO NOT SCALE

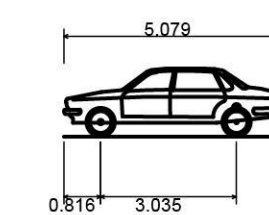

Large Car (2006)  
 Overall Length 5.079m  
 Overall Width 1.872m  
 Overall Body Height 1.525m  
 Min Body Ground Clearance 0.310m  
 Max Track Width 1.831m  
 Lock to lock time 4.00s  
 Kerb to Kerb Turning Radius 5.900m

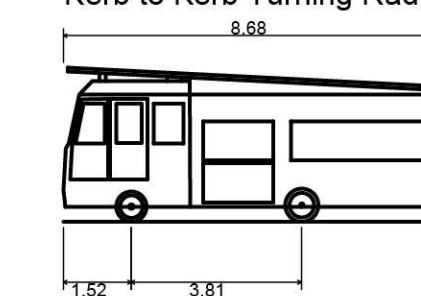

DB32 Fire Appliance  
 Overall Length 8.680m  
 Overall Width 2.180m  
 Overall Body Height 3.452m  
 Min Body Ground Clearance 0.337m  
 Max Track Width 2.121m  
 Lock to lock time 6.00s  
 Kerb to Kerb Turning Radius 7.910m

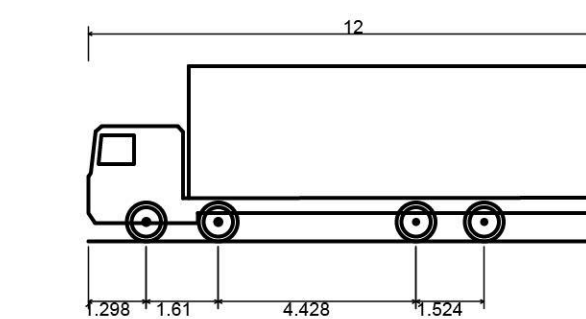

Rigid Truck  
 Overall Length 12.000m  
 Overall Width 2.500m  
 Overall Body Height 3.928m  
 Min Body Ground Clearance 0.412m  
 Track Width 2.471m  
 Lock to lock time 6.00s  
 Kerb to Kerb Turning Radius 11.900m

|     |            |    |                     |     |     |
|-----|------------|----|---------------------|-----|-----|
| PO2 | 11/12/2020 | DC | TRACK PLOTS UPDATED | ... | ... |
| P01 | 07/12/2020 | DC | FIRST ISSUE         | ... | ... |
| REV | DATE       | BY | DESCRIPTION         | CHK | APP |

DRAWING STATUS: S3 - FOR REVIEW

**wsp**  
 1 Capital Quarter, Tynhall St, Cardiff, CF10 4BZ, UK  
 T+44 (0) 292 078 9200  
 wsp.com

CLIENT: ILKE HOMES

ARCHITECT: ROBERTS LIMBRICK

SITE/PROJECT: HOLMER ILKE HOMES

TITLE: VEHICLE TRACKING SHEET 2 OF 2

|             |             |           |    |           |     |
|-------------|-------------|-----------|----|-----------|-----|
| SCALE @ A1: | NTS         | CHECKED:  | PG | APPROVED: | LH  |
| PROJECT NO: | 70062561    | DESIGNED: | PG | DRAWN:    | DRC |
| DATE:       | December 20 |           |    |           |     |

DRAWING NO: HIH-WSP-XX-XX-C-DR-0120a

REV: P02

© WSP UK Ltd

File name: Z:\062561\0062561 - HOLMER ILKE HOMES\03 WPC\01 CIVIL ENGINEERING\02 CAD\BIN MODEL\HIH-WSP-XX-XX-C-DR-0120a.DWG, printed on 11 December 2020 13:38:35, by Chloe Dyer